

# Level Measurement *prolevel FMC 661*

**Single-channel transmitter for field mounting  
For capacitive or hydrostatic probe  
Limit switch input and calibration compensation  
System integration via Rackbus RS-485 interface**



Prolevel FMC 661 with  
separate limit switch  
input in IP 66 housing

## Application

- The Prolevel FMC 661 measures level in liquids and bulk solids using a capacitive or hydrostatic probe. The transmitter, designed for mounting in the field, determines level, calculates volume and monitors limit levels
- Separate limit detection: double protection from overspill, independent empty indication or level measurement with automatic compensation for changing media
- System integration via the Rackbus RS-485 interface.

## Features and Benefits

- Economical transmitter for field mounting with IP 66 protection
- Simple start-up, simple operating matrix, can be configured by Endress+Hauser operating and display programs
- Reliable operation: function monitoring of probe and transmitter.

Endress + Hauser

Nothing beats know-how



## Measuring System

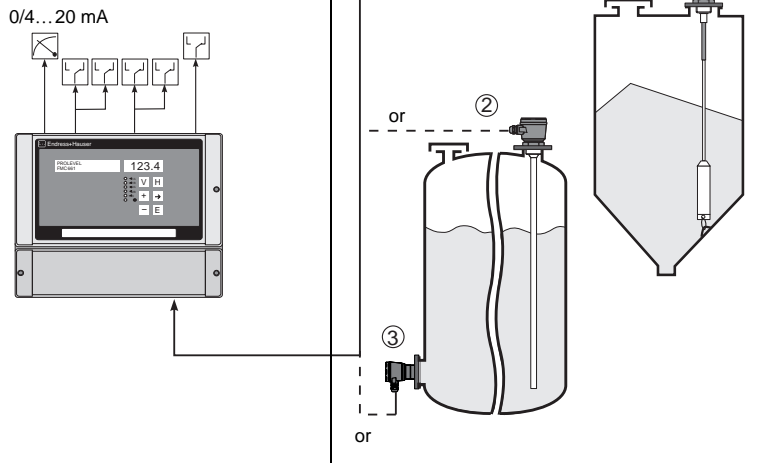

Capacitive level measurement  
 ① in silo or  
 ② in tank.  
 Hydrostatic level measurement  
 ③ in open tank

## Measuring System

- Prolevel FMC 661 and
- one *capacitive probe* with electronic insert EC 37 Z or EC 47 Z or one Deltapilot S *hydrostatic pressure sensor* with electronic insert FEB 17
- a capacitive or vibration probe can also be connected as a separate limit switch.

## Hazardous Areas

Provided it is used with a certified transmitter (in preparation) a certified probe or sensor can be mounted in hazardous areas.

## Separate Limit Switch

A separate limit switch can be used for independent limit detection or for automatic calibration compensation.

### Automatic calibration compensation

The Prolevel corrects the calibration every time the limit switch is actuated. If the product properties change, then the correction increases the accuracy of measurement (changes in density for hydrostatic measurement or changes in the electrical properties for capacitive measurement).

Limit switch for Prolevel FMC 661	
Capacitive probe	e.g. Multicap probe with EC 16 Z or EC 17 Z
Vibration probe	Liquiphant II FDL 30 / FDL 31 / FDL 35 / FDL 36  Soliphant II FTM 30 S / FTM 31 S FTM 32 S

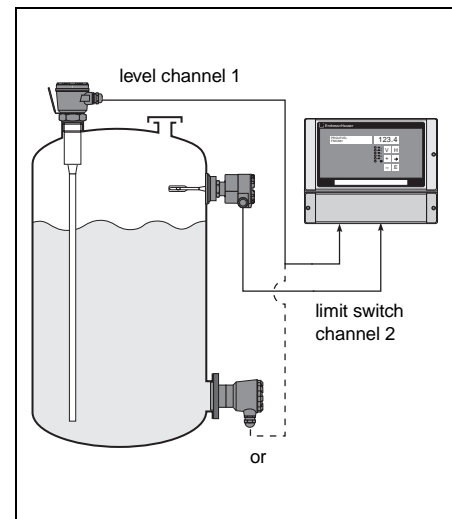

Level measurement with separate limit detection

## Analogue Output

The Prolevel transmitter provides a standard 0 to 20 mA signal (switchable to 4 to 20 mA). Depending upon calibration, this is proportional to either level or volume. The start and end of the signal range can be programmed as required.

## Relay Outputs

The Prolevel is equipped with five relays, each with a potential-free changeover contact.

- two sets of two limit relays with adjustable switch point and hysteresis
- one alarm relay.

## Additional System Components For Rackbus RS-485 Interface Option

### Hardware

- RS-485 interface card or RS-232C/RS-485 converter for connection to a personal computer
- FXA 675 interface card for connection to the Rackbus

### Software for personal computers

- Fieldmanager 485: configuration and display program for small and medium-sized plants
- Commugraph: easy-to-use visualisation program with limit value display.

# System Integration

Connection to personal computer. Prolevel transmitters are also available with two channels

- ① capacitive probe
- ② limit switch
- ③ hydrostatic probe

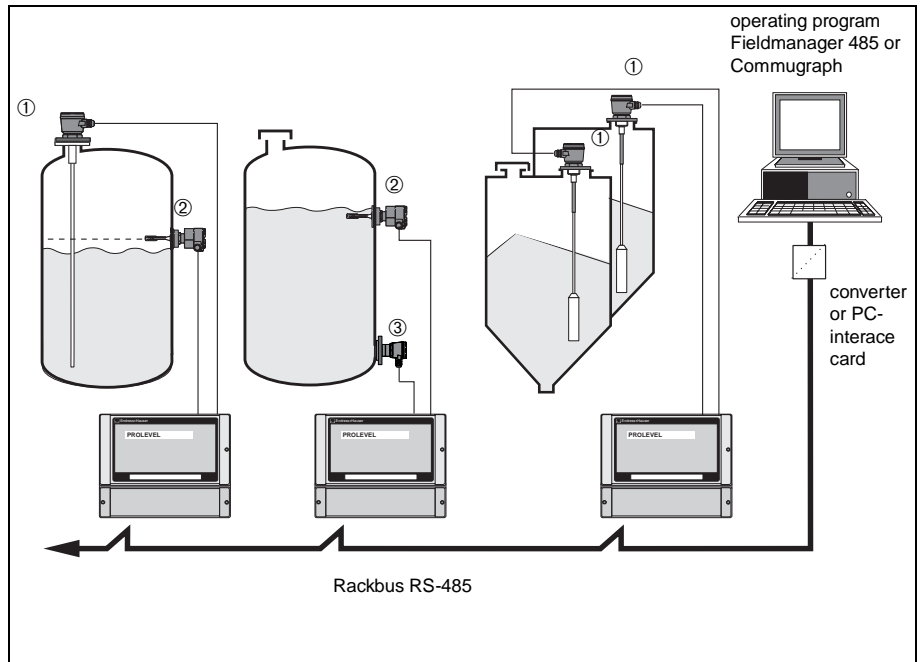

## Personal Computer

Transmitters equipped with a Rackbus RS-485 interface can be connected to a personal computer via the Rackbus RS-485 bus. A measuring system then comprises:

- Several Prolevel measuring points (or other units with Rackbus RS-485 interface)
- PC connection (RS-485 interface card or a RS-232C/RS-485 converter).

Depending on the system topology, up to 25 transmitters – also multichannel – can be connected at various points on the bus, which may be up to 1200 m long.

## Process Control Systems

The Prolevel FMC can be easily and economically integrated into existing industrial process control systems. Individual Rackbus RS-485 buses, each with up to 25 transmitters, are connected to the Rackbus via the FXA 675 interface card (exceptionally via Monorack RS-485). A gateway connects the Rackbus to standard supervisory systems such as PROFIBUS, FIP or MODBUS.

Integration into process control systems: Two Rackbus RS-485 buses can be connected to the Rackbus via the FXA 675 interface card. A gateway connects the Rackbus to a supervisory system

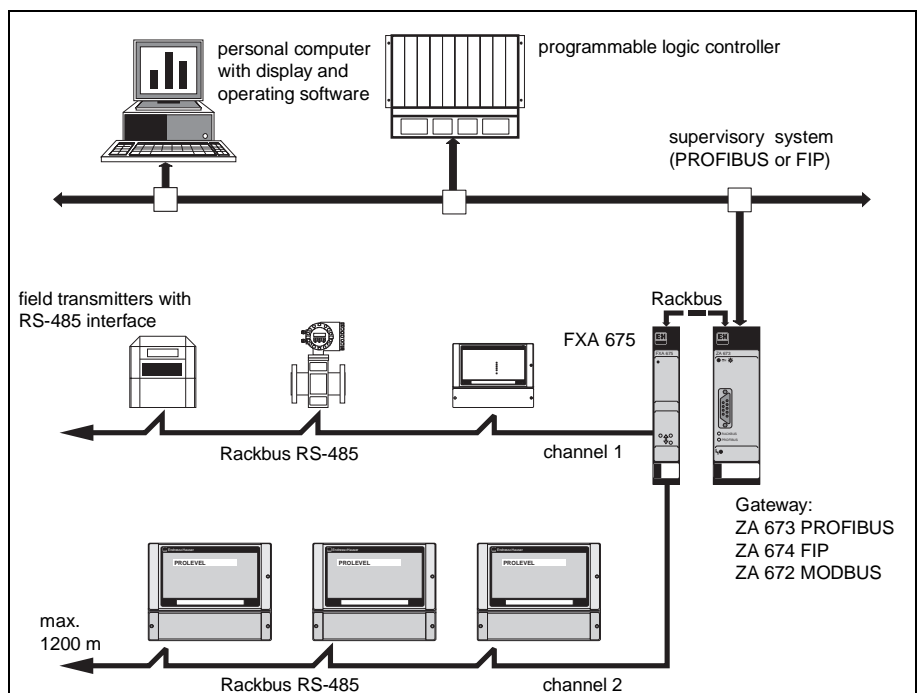

# Operating Principle

## Capacitance Measurement

The probe and vessel wall (or counter-electrode) form a capacitor with a defined capacitance, which is low when the probe is uncovered. As soon as material covers the probe, the capacitance between the probe and the vessel wall increases while the corresponding resistance decreases. The parallel circuit of capacitor and resistor – i.e. the impedance – is used for measurement.

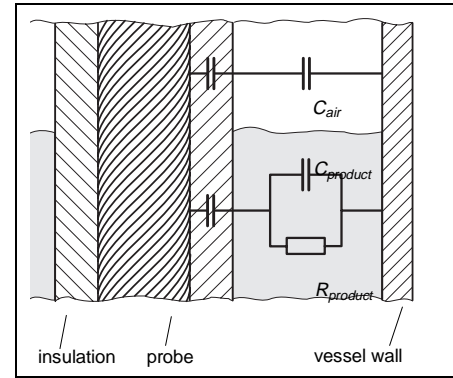

Capacitive measurement principle

## Hydrostatic Pressure Measurement

Hydrostatic pressure is created by the weight of a column of liquid. When the density  $\rho$  is constant, the pressure acting on the sensor is simply a function of the height  $h$  of the column.

$$p_{hydrostatic} = \rho \cdot g \cdot h$$

- $\rho$  = density
- $g$  = acceleration due to gravity
- $h$  = distance between the surface of the liquid and the centre of the sensor diaphragm

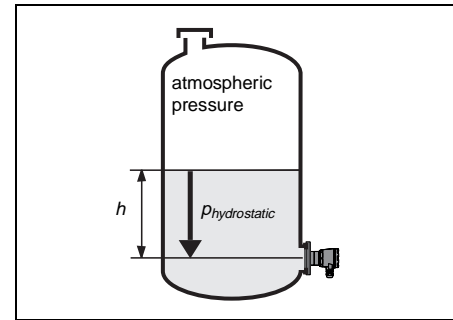

Hydrostatic measurement principle

## Signal Processing

The Prolevel provides the sensor with power over an unshielded two-wire cable. The sensor supplies an interference-free, level proportional, pulse frequency modulated (PFM) signal via the same cable. The measured value derived from this signal is displayed at the transmitter and output as a standard 0/4...20 mA signal. It may also be read by a Commulog VU 260 Z handheld terminal or passed on to a supervisory system via the optional Rackbus RS-485 interface.

## Function Monitoring

The Prolevel transmitter monitors the complete measuring system from the sensor to the outputs. On fault condition:

- the alarm relay de-energises and the corresponding LED lights
- the current falls to -10%, rises to +110% or holds the last value (programmable)
- the limit relays respond according to the fail-safe mode selected or de-energise (programmable).

## Simple Linearisation

A linearisation is made by entering a vessel characteristic which describes the relationship between the height  $h$  and volume  $V$  of the vessel.

The most common application – a horizontal cylinder – is pre-programmed in the transmitter. A linearisation table for any other vessel shape, e.g., a tank with a conical outlet, can be simply programmed by entering up to 30 reference points.

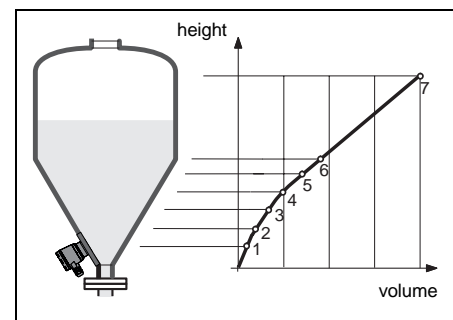

Entering a linearisation table. The vessel characteristic is described by 3... 30 reference points

## Selection/Design

### Transmitter Selection

Prolevel can be selected according to the requirements of the measuring point:

- Economical version without display or keypad; can be operated by the Commulog VU 260 Z handheld terminal
- Version with display (also illuminated) and keypad
- Version with Rackbus RS-485 interface option for system integration and remote operation of the transmitter.

### Prolevel Product Family

Prolevel transmitters are also available for two continuous level measurements on separate channels (separate limit detection with FMC 661 only):

- For two capacitive probes: Prolevel FMC 662
- For two hydrostatic probes: Prolevel FMB 662.

For further information see last page.

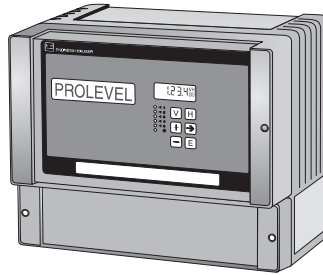

Prolevel with display and keypad

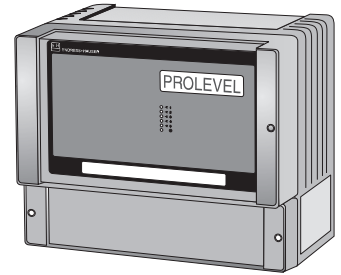

Cost-effective versions without display or keypad

## Dimensions

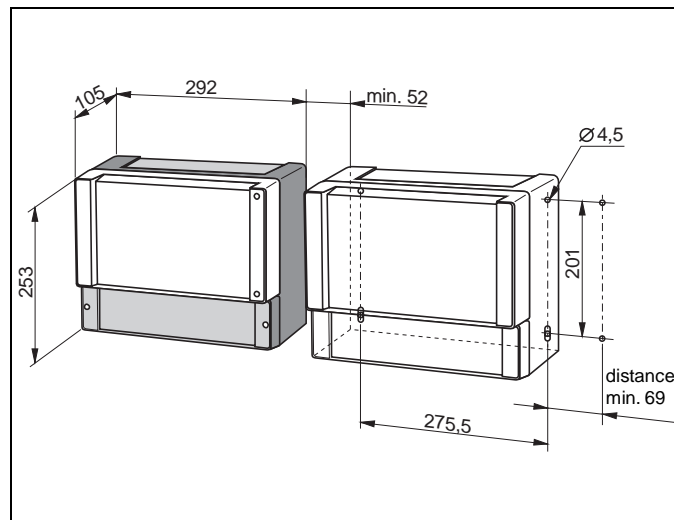

Dimensions and space required for mounting the IP 66 housing

## Installation

### Mounting

Housing with protection IP 66:

- For wall-mounting
- For post-mounting on a 1" or 2" pipe (see page 15, »Accessories«).

An all-weather hood is available for mounting in the open (see page 15, »Accessories«).

### Hazardous Areas

Probes and sensors with appropriate certification may be installed in explosion hazardous areas. The transmitter must always be installed outside the explosion hazardous area. All local regulations concerning installation must be observed.

# Electrical Connection

## Terminal Strip

The terminal strip, suitable for cable cross-sections up to 2.5 mm<sup>2</sup>, is located in a separate connection compartment. The cable entries are prestamped for easy removal (5 x Pg 16; 4 x Pg 13.5 at bottom; 4 x Pg 16 at rear).

## Power Supply

- AC: 85...253 V 50/60 Hz or 20...55 V, 50/60 Hz or DC: 16...60 V (residual ripple within tolerance), integrated reverse polarity protection
- Power consumption: maximum 7 W.

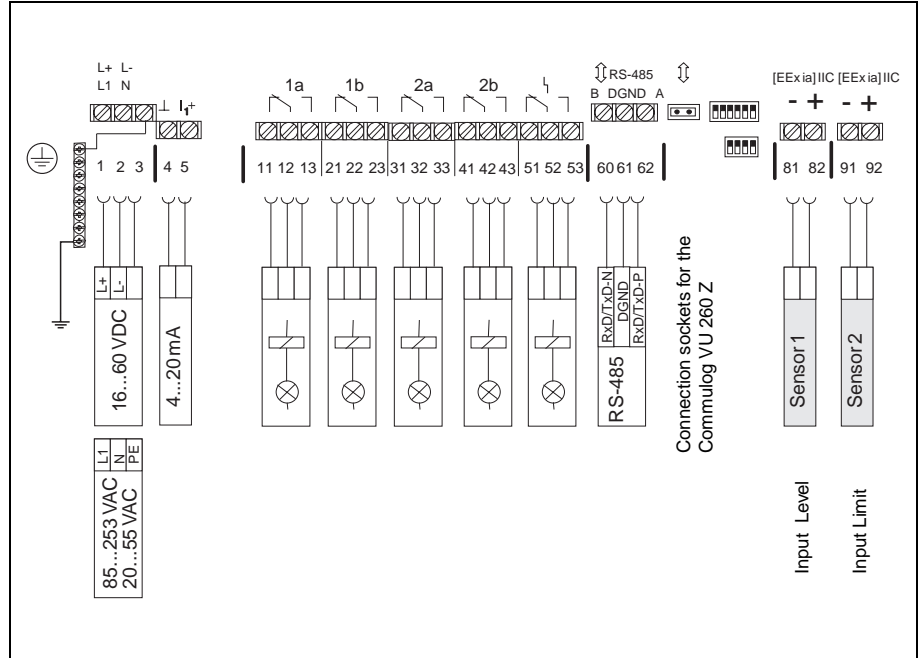

Terminal strip of the FMC 661 — the electrically isolated circuits are indicated by thick black lines

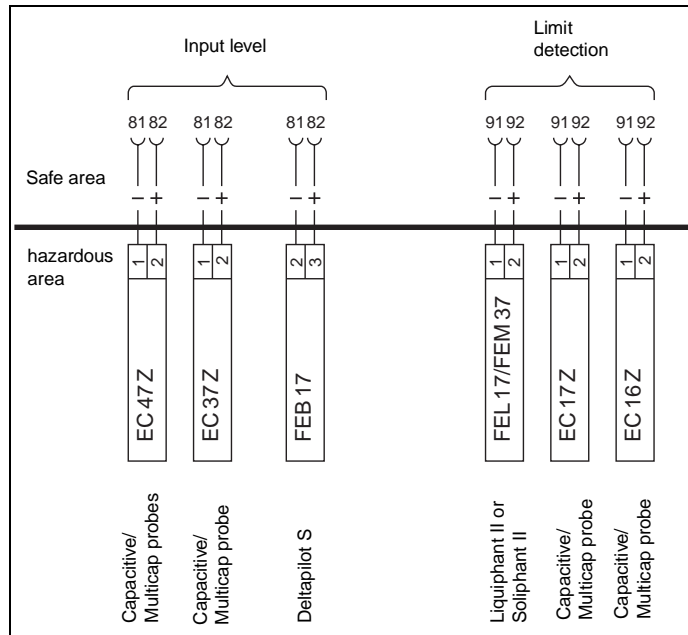

Sensor and probe connection

**External Limit Switch**

An external limit switch, e.g. Multicap probe, Liquiphant II or Soliphant II, can be connected to terminals 91 and 92. Cable: standard two-wire cable screened or unshielded depending on the environment, max. 25 Ω per core (cross-section of cable larger than 0.75 mm<sup>2</sup> for 1000 m).

**Electrical Isolation**

Current output, relay outputs, power supply, sensor input and bus inputs are electrically isolated from each other (safe isolation to DIN/VDE 0160). Both sensor inputs are intrinsically safe and electrically isolated from each other.

**Hazardous Areas**

When laying cables in hazardous areas, the maximum permissible values for U, I, R, L, C (see Certificate of Conformity) and all local regulations are to be observed.

**Overvoltage Protection**

The external overvoltage protection unit HAW 262 for signal outputs is recommended for protecting the transmitter from voltage peaks, especially when it is mounted in the field. The overvoltage protection unit HAW 261 should be used to protect against mains power voltage peaks.

**Electromagnetic Compatibility**

The interference immunity of the Prolevel has been checked to a test strength of 10 V/m. The signal deviation over the total frequency range of 10 kHz to 1 GHz is always less than 1%. Over wide frequency ranges the deviation is significantly lower.

**Bus Installation**

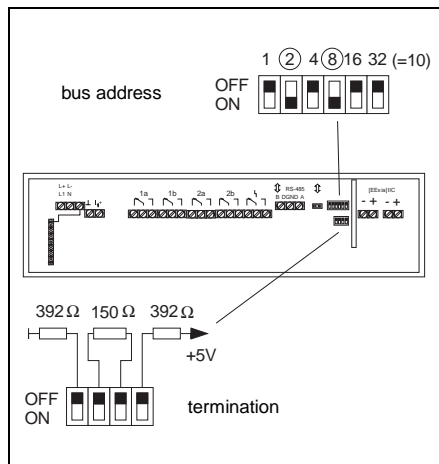

Bus address and terminal resistance switch of the Prolevel. The setting shown is standard for all Prolevel transmitters except the last one on the bus

**Rackbus RS-485**

Normally, up to 25 Prolevel transmitters can be connected to the bus: the actual number depends upon the topology and conditions of operation. The bus connection requires:

- connecting cable (two-core, twisted and screened)
- cable length: max. 1200 m.

**Bus Address**

Every transmitter is given a unique address which is configured at the DIP switches at the terminal strip.

**Termination**

For reliable transmission of the communication signal:

- set the terminal resistance at the PC board and the furthest Prolevel from the board to 150 Ω.

The bus power is provided by the PC interface card or RS-232C/RS-485 adapter.

# Bus Installation (continued)

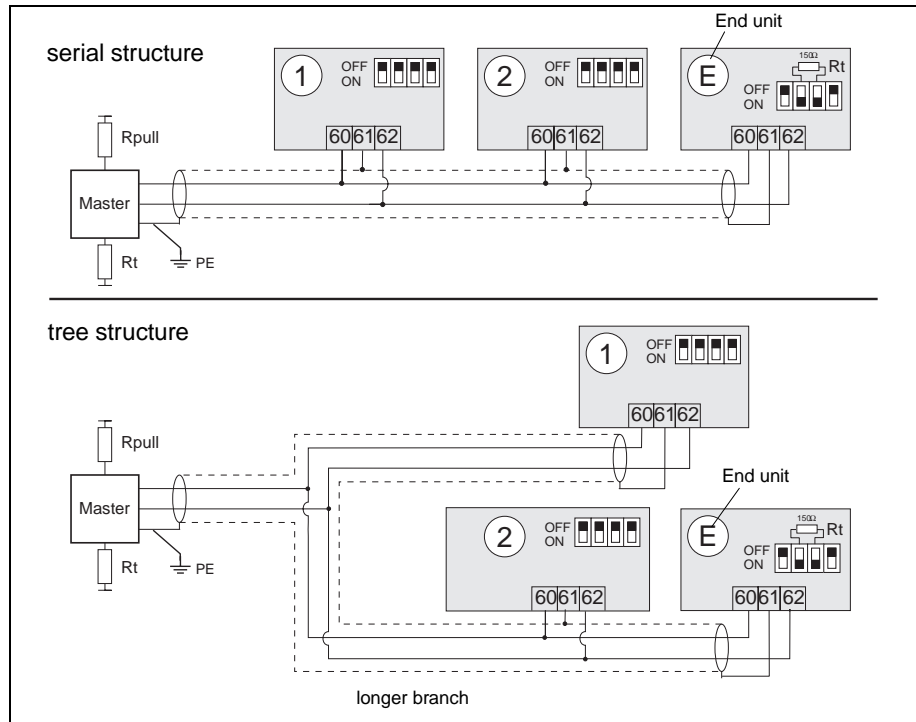

Bus topology.  
The master is a PC interface card or converter

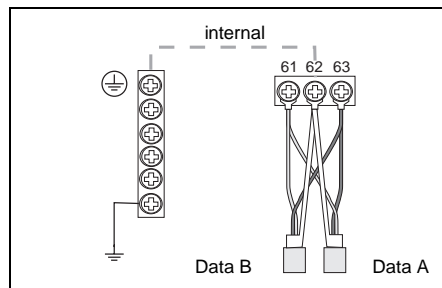

Example for wiring the bus to the Prolevel

## Bus Topology

When planning the system, attention should be paid to the possible segmentation of the bus according to individual plant sections. Suitable topologies are:

- Serial, max. 1200 m,
- Tree of total length 1200 m.

The bus screening must have electrical continuity throughout the bus.

## Personal Computer

A personal computer is connected up using either a RS-485 PC interface card or an RS-232C/RS-485 converter (both with electrical isolation).

## RS-485 PC Interface card

The card is configured for use as the COM 3 interface port. Also supplied for the bus connection is a 25-pin plug with screw terminals:

- Terminal 1: Bus screening
- Terminal 17: Data A (RxD/TxD-P)
- Terminal 16: Data B (RxD/TxD-N).

Wiring the plug for the PC interface card

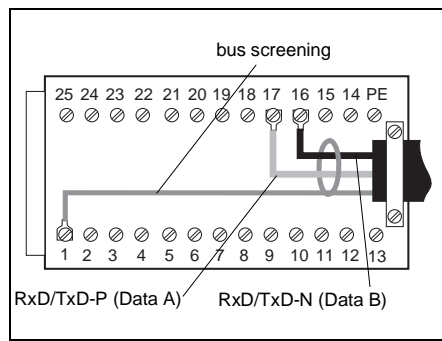

## RS-232C/RS-485 Converter

The bus connector is supplied with a 9-pin plug with screw terminals:

- Terminal 5: Bus screening
- Terminal 3: Data A (RxD/TxD-P)
- Terminal 8: Data B (RxD/TxD-N).

Wiring the plug for the RS-232C/RS-485 converter

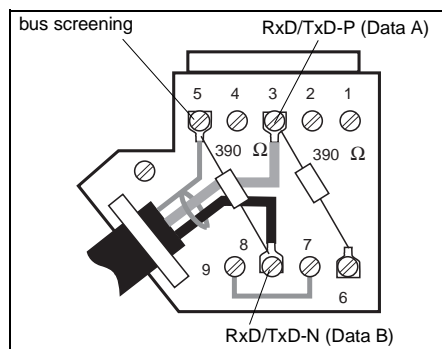



# Operation

## Simple Operation

The six keys on the front panel are used to configure the instrument or call up measured values: parameters are displayed on the 4-digit LC-display.

The transmitter is configured via an operating matrix, whereby each field is selected by the **V** (vertical) and **H** (horizontal) keys. Parameters are entered using only three keys **+**, **-**, **→**: pressing the **E** key stores and registers the entered value.

## Operating Matrix

Whether configuration of the Prolevel is done via the keypad, with the handheld terminal or remotely via the Rackbus RS-485 interface, the easy-to-use operating matrix ensures programming procedures are uniform and clear. An in-depth knowledge of Endress+Hauser instrumentation is not needed to quickly configure the transmitter.

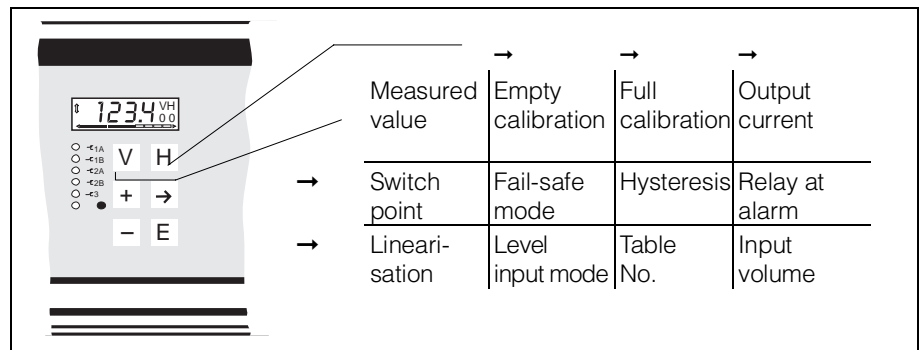

Prolevel is configured by entering only a few parameters

## Handheld Terminal

All Prolevel transmitters can be operated by the Commulog VU 260 Z handheld terminal, which displays parameters, measured values and operating status. Its large display gives simple, self-explanatory information on all parameters in the language selected when ordering. The transmitter continues to measure normally while data are entered or read.

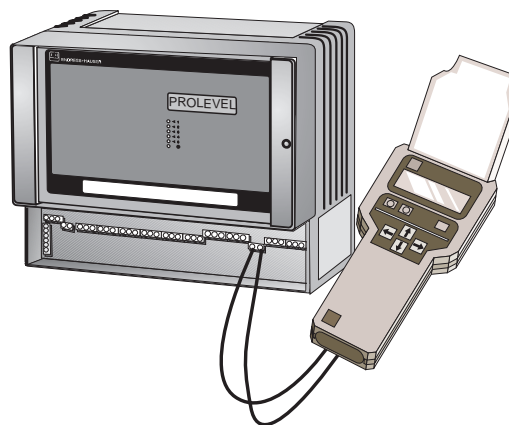

Prolevel without keypad. The communication sockets for the Commulog VU 260 Z handheld terminal are located in the connection compartment

# Operating Program

Section of operating matrix used for configuring the Prolevel FMC 661 (Fieldmanager 485)

Prolevel No. 2 FMC 671 LIC 001 VH-Position: 00

Measured value	Empty »calibration«	Full »calibration«	Output current
Relay 1 switch point	Relay 1 fail-safe mode	Relay 1 hysteresis	Relay 1 at alarm
Linearisation	Level input mode	Tab. No.	Input volume
Calibration mode	Offset	Sensitivity	

Select VH pos. with cursor keys - or press ESC and enter VH pos.  
To configure press RETURN key

F1: Dev 0-31  
F2: Dev 32-63

F3: Dev.Adr  
F4: COM port

F5: Envelope  
F6: Matrix

F7: Bargraph  
F8: Up/Down

F9: Terminal  
F10: Exit

## Remote Operation and Display

Prolevel transmitters with a Rackbus RS-485 interface can be operated from personal computer. Each transmitter is accessed on-line via its individual bus address. The operating program uses the standard operating matrix in which each parameter field can be quickly and easily selected.

## Fieldmanager 485 Operating Program

The Fieldmanager 485 operating program is a simple, economical configuration and display system for small and medium-sized plants. It can run on any AT personal computer having an MS-DOS operating system. A self-explanatory menu, available in English and other languages, offers a total of nine menus for the following functions:

- Summary of connected and operative transmitters - the so-called live list
- Selection of the Prolevel transmitters
- Configuration and calibration of the transmitters via the operating matrix
- Presentation of measured values as moving columns
- Back-up of configurations by the up/download functions
- Setting of the COM port
- Terminal program for on-line communication with individual transmitters.

Live list of connected transmitters  
Shown are the individual instrument addresses on the Rackbus (Column 1), transmitter designations (Column 2) the customer's measuring tag names (Column 3)

Fieldmanager 485 Endress+Hauser Version 5.1

No.	Device	Measuring points	
00	FMC 671	LIC 001	LIC 002
01	FMC 672	LIC 003	LIC 004
02	FMC 672	LIC 005	LIC 006
03	FMC 672	LIC 007	LIC 008
04	FMC 672	LIC 008	LIC 009
05	----		
06	----		
07	----		
08	----		
09	----		
10	FMC 672	LIC 101	LIC 102
11	FMC 672	LIC 103	LIC 105
12	FMC 672	LIC 104	LIC 105
13	----		
14	----		
15	----		
17	----		
18	----		
19	----		
20	----		
21	----		
22	----		
23	----		
24	----		
25	----		
26	----		
27	----		
28	----		
29	----		
30	----		
31	----		
32	----		

F1: Dev 0-31  
F2: Dev 32-63

F3: Dev.Adr  
F4: COM port

F5: Envelope  
F6: Matrix

F7: Bargraph  
F8: Up/Down

F9: Terminal  
F10: Exit

Display of measured values of two Prolevel units using the operating program Fieldmanager 485

Fieldmanager 485 Endress+Hauser Version 5.1

00: LIC 001

75.5 %

Error code: 0

01: LIC 003      LIC 004

23.7 %      58.0 %

Error code: 0

Alt F1 - Select
Alt F2 - Select

F1: Dev 0-31  
F2: Dev 32-63

F3: Dev.Adr  
F4: COM port

F5: Envelope  
F6: Matrix

F7: Bargraph  
F8: Up/Down

F9: Terminal  
F10: Exit

# Visualisation

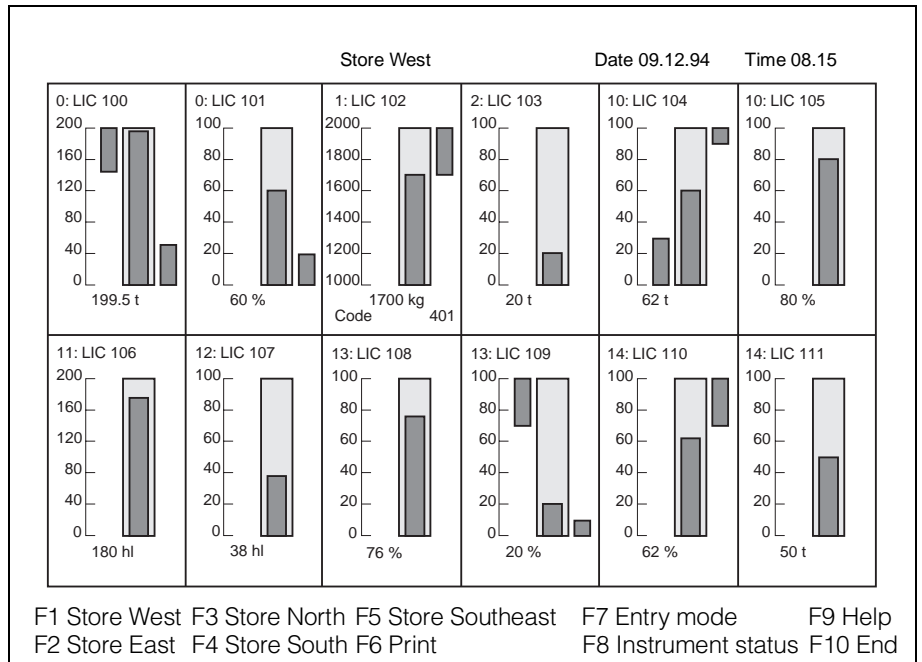

Display of a measured value group — function keys simplify operation

## Commugraph

The Commugraph visualisation program is the ideal support tool for the operating program. It is easily installed and operated. The principle functions are as follows:

- Analogue display of measured values as columns. 12 measuring points can be displayed simultaneously, 60 in all
- Transmitter status display
- Limit value display. When the limit value is exceeded, the column changes from green to red
- Level display as numerical value with technical units
- List of connected transmitters
- Printed log of measured values.

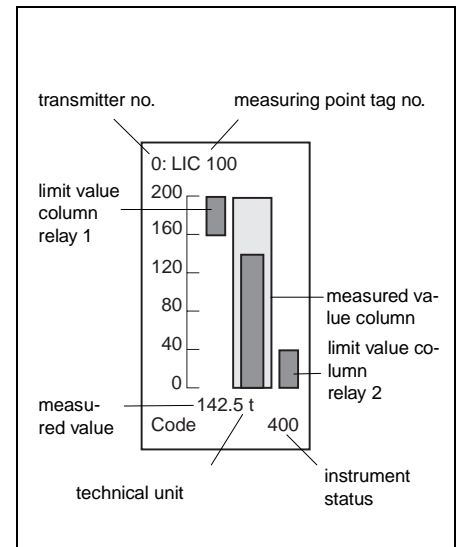

Display for individual measurement point

No.	Meas. point	Contents	Meas. val.	Units	Factor
0	LIC 100	Rain retention basin 1	1.58	m	1
0	LIC 101	Rain retention basin 2	0.00	m	1
1	LIC 102	Rake control	0,02	m	1
2	LIC 103	Inflow measurement	780	l/sec.	1
10	LIC 104	Presettling basin 1	3.78	m	1
10	LIC 105	Presettling basin 2	3.82	m	1
11	LIC 106	Filter basin 1	1,95	m	1
12	LIC 107	Filter basin 2	1,87	m	1
13	LIC 108	Digestion tank	2824	m <sup>3</sup>	1
13	LIC 109	Flocculant	1230	mm	1
14	LIC 110	Neutralisation NaOH	2100	mm	1

Printout of measuring points and their measured values

No.	Meas. point.	Code	Status text
0	LIC 100	LIC 101 0	Operating mode...
1	LIC 102	401	None...
2	LIC 103	0	Operating mode...
3			@04, 03,...
4			@04, 04,...
5			@04, 05,...
6			@04, 06,...
7			@04, 07,...
8			@04, 08,...
9			@04, 09,...
10	LIC 104	LIC 105 0	Operating mode...
11	LIC 106	0	Operating mode...
12	LIC 107	0	Operating mode...
13	LIC 108	LIC 109 0	Operating mode...
14	LIC 110	0	Operating mode...

Display of transmitter status

# Technical Data

## General specifications

Manufacturer	Endress+Hauser GmbH+Co. D-79689 Maulburg
Designation	Prolevel FMC 661
Function	Transmitter for level measurement with capacitive or hydrostatic probe, separate limit switch
Input signal	two PFM signals
Interface	0/4 to 20 mA, Communication with VU 260 Z handheld terminal, Rackbus RS-485 (optional)
Reference conditions	To DIN IEC 770 (T <sub>U</sub> = 25 °C) or as specified
Other	CE mark

## Input characteristics

### Input for probe for level measurement (Channel 1)

Signal	Pulse frequency modulated (PFM); current pulses, which are superimposed on the base current. Electronic insert: – for capacitive probe: EC 37 Z or EC 47 Z – for hydrostatic probe: FEB 17
Explosion protection	CENELEC [EEx ia] IIC, FM AIS, CSA AIS
Intrinsically safe electrical isolation	Between sensor circuit and other electronics as well as to Channel 2

### Separate switch input (Channel 2)

Signal	Pulse Frequency Modulation (PFM); current pulses, which are superimposed on the base current. Electronic insert for limit switch: – Capacitive probe: e. g. Multicap probe with EC 16 or EC 17 Z – Vibration probe: Liquiphant II FDL 30 / FDL 31 / FDL 36 or Soliphant II FTM 30 S / FTM 31 S / FTM 32 S
Explosion protection	CENELEC [EEx ia] IIC, FM AIS, CSA AIS
Intrinsically safe electrical isolation	Between sensor circuit and other electronics as well as to Channel 1

## Output characteristics

### Analogue output

Output	0... 20 mA, switchable to 4... 20 mA Signal underflow: -2 mA Signal overflow: 22 mA
On alarm	Switchable +110%, -10% or hold last measured value
Electrical isolation	Analogue output electrically isolated from the CPU and the other electronics
Current limitation	23 mA
Temperature coefficient	0.3%/10 K of range end value
Warm-up time	1 s
Adjustable damping	0 to 99 s (T <sub>90</sub> – time)
Maximum load	600 Ω
Load effect	negligible

### Relay

Version	5 relays, each with a potential-free changeover contact
Relay function	2 sets of 2 limit relays, each set monitoring a limit value 1 alarm relay (de-energises on fault condition)
Hysteresis	Switch points and switching hysteresis of limit relays freely adjustable, fail-safe mode selectable minimum or maximum
Switching capacity	AC: 6 A, 250 V, 750 VA at cos φ=0.7 1500 VA at cos φ= 1 DC: 6 A, 250 V, 200 W
Electrical isolation	Relays electrically connected to each other, electrically isolated from other electronics

**Output characteristics (continued)****Displays**

Display (LCD)	4-digit measured value display with optional lighting and bargraph (analogue display of current with 10 segments)
LEDs	One yellow LED for every limit relay to indicate its switching status: LED lit indicates "relay energised". One red LED for the alarm relay: LED lights on alarm and flashes on warning (LED lit indicates alarm relay de-energised). One green LED indicates power on.

**Communication interfaces**

Keypad	6 keys (optional)
Rackbus RS-485 interface (optional)	No. of units: maximum 25. When using other Endress+Hauser instruments with Rackbus RS-485 interface the following applies: – max. 25 units when mounted in safe areas – max. 10 units when one or more mounted in a hazardous area Baud rate: 19 200 bit/s, fixed Cable: screened, twisted pairs (screen connected to DGND on Prolevel) Topology: serial bus, electrically isolated, tree structure optional Length: max. 1200 m, including taps or branches (taps under 3 m do not count) Transmitter address: via 6-pole DIL switches in connection compartment Termination: via 4-pole DIL switches in connection compartment Electrical isolation: bus inputs are electrically isolated from the other electronics
Commulog VU 260 Z handheld terminal (standard)	Communication sockets in connection compartment

**Power supply**

Power supply	AC: 85...253 V, 50/60 Hz or 20...50 V, 50/60 Hz or DC: 16...60 V, residual ripple within the permissible voltage range
Power consumption	maximum 7 W
Safe electrical isolation	Between power supply and signal output, CPU, Rackbus RS-485 interface, relay and other electronics

**Environmental conditions**

Temperature ranges	Nominal temperature : –0 to 60 °C Limiting temperature : –20 to 60 °C Storage temperature: –40 to 80 °C
Electromagnetic compatibility	better than 1% of full scale value. Immunity to EN 50082-2 (E 1993, VDE 0839 Part 82-2) Emission to EN 50081-2, industrial range (VDE 0839 Part 81-1), industrial standard NAMUR, with 10 V/m
Climatic class	To DIN 40 040 Tab. 10 "R": unit in the open or in outside areas. Annual average humidity 95%, dew permissible
Vibration resistance	To DIN 40 040 Tab. 6 "W"
Protection	IP 66 with closed housing and cable glands of same protection type (with open housing IP 40, with open connection compartment IP 20)
Wetted parts	Housing body PC (polycarbonate)/ABS (Acrylnitrile Butadiene Styrol), RAL 5012 (blue) Transparent cover PC (polycarbonate) blue front panel with field for labelling Sealing of body in PU soft foam, FCC-free, for sealing the cover

**Mechanical specifications**

Electrical connection	Pre-stamped cable glands: rear wall or base for each 5 or 4 cable entries Pg 16, additional 4 cable entries Pg 13.5 on base. Terminal connections for cable diameter 2.5 mm <sup>2</sup>
Connection cable for probe or switching input	Two-wire, unscreened, maximum 25 Ω per core
Housing	For wall or post mounting
Dimensions (L x H x W)	292 mm x 253 mm x 176 mm
Position	Vertical recommended
Weight	2.45 kg

## Prolevel FMC 661

### Certificate

- R Standard (non-certified)
- G CENELEC [Ex ia] IIC
- N FM Intrinsically Safe, Class I, II, III;  
Division 1; Groups A, B, C, D, E, F, G
- Q CSA Intrinsically Safe, Class I, II, III;  
Division 1; Groups A, B, C, D, E, F, G

### Housing / Cable entry

- 1 Plastic field housing (ABS) IP 66 /  
prestamped cable entries for cable glands  
with Pg 13.5 or Pg 16
- 9 Other

### Display / Operation

- A With display / with keypad in field housing
- B With illuminated display / with keypad in field housing
- C Without display / without keypad, operation via  
Rackbus RS-485 (option) or VU 260 Z handheld terminal
- Y Other

### Relays

- 2 Five relays each with potential-free changeover contact:  
two sets of two relays for monitoring limit values,  
one alarm relay
- 9 Other

### Power supply

- A AC 85...253 V, 50/60 Hz
- B AC 20...55V, 50/60 Hz
- C DC 16...60V
- Y Other

### Communication

- 1 Connection for Commulog VU 260 Z
- 2 With Rackbus RS-485 interface /  
connection for Commulog VU 260 Z
- 9 Other

FMC 661 - [ ] [ ] [ ] [ ] [ ] [ ] [ ] Product designation

## Supplementary Documentation

- Deltapilot S  
System Information SI 026F/00/e
- Multicap T  
Product Information PI 009F/00/e
- Liquiphant  
System Information SI 007F/00/e
- Soliphant II  
System Information SI 024F/00/e
- Rackbus  
System Information SI 014F/00/e
- Commute operating program  
Technical Information TI 113F/00/e
- Commugraph  
Technical Information TI 158F/00/e
- Rackbus-RS-485 Interface and  
FXA 675 Monorack II RS-485  
Technical Information TI 221F/00/e
- Modbus Gateway ZA 672  
Technical Information TI 148F/00/e
- Profibus Gateway ZA 673  
Technical Information TI 162F/00/e
- FIP Gateway ZA 674  
Technical Information TI 167F/00/e
- Rackbus RS-485  
Operating manual BA 134F/00/e

# Accessories

## All-Weather Protective Hood for the Field Housing

Material:

- aluminium (Order No. 919567-0000) blue lacquered finish
- stainless steel 1.4301 (Order No. 919567-0001).

Weight: approx. 1 kg.

Mounting screws supplied.

## Post Mounting

Material:

- galvanised steel (Order No. for 2" pipe: 919566-0000; for 1" pipe: 919566-1000)
- stainless steel 1.4301 (Order No. for 2" pipe: 919566-0001; for 1" pipe: 919566-1001).

Weight: approx. 1 kg.

Mounting screws and nuts supplied.

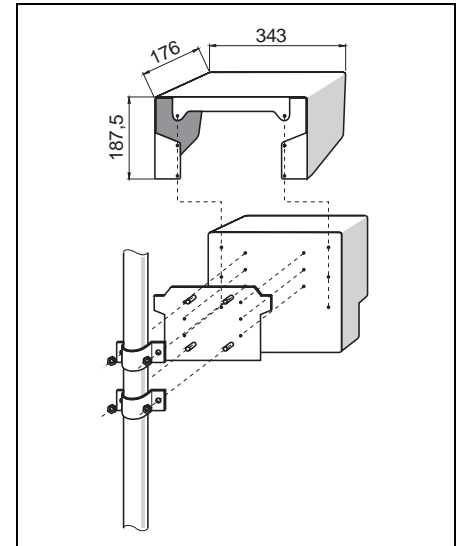

Mounting and dimensions for the all-weather cover. Mounting to a 2" post

## Commulog VU 260 Z

Handheld terminal for calibrating the Prolevel version without display or keypad (see Technical Information TI 140/00/e).

## Overvoltage Protection

Separate overvoltage protection unit HAW 261 and HAW 262 (see Technical Information TI 108F/00/e).

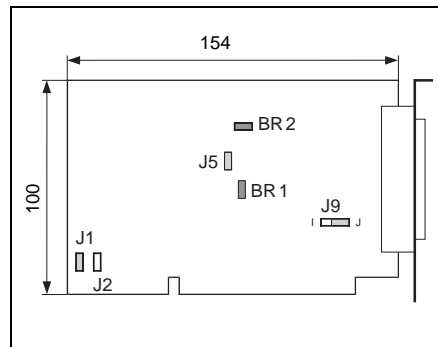

Dimensions of the RS-485 PC interface card and position of the jumpers (grey = default)

## RS-485 PC Interface Card

- Connector: 25-pin Min-D plug, pin assignment: see figure on page 8, plug supplied with screw terminals
  - Baud rate: 19 200 bit/s
  - Configuration: supplied configured for COM 3, address 3E8H, with protective ground at Pin 1 of connector
  - Slot: 8 or 16 bit
  - RS-485 output electrically isolated
- Order No. 016399-0000

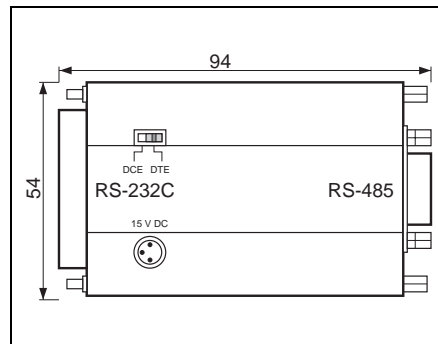

Dimensions of the converter

## Converter: RS-232C/RS-485 Interface

- Connector for PC: 25-pin Min-D plug
- for bus 9-pin Min-D jack, pin assignment on bus side, see figure page 8, plug supplied with terminal screws
- Baud rate: 19 200 bit/s
- RS-485 output electrically isolated
- Power supply 15 V DC; power unit 230 V or 115 V to order
- RS-232C interface, can be configured as DCE/DTE

Order No. 016398-0000 for 230 V / 016398-0050 for 115 V

# Product Line

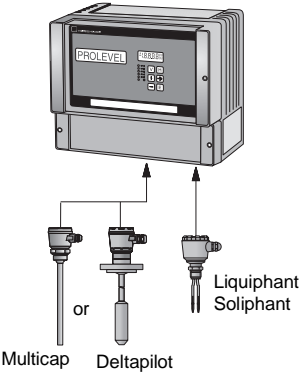
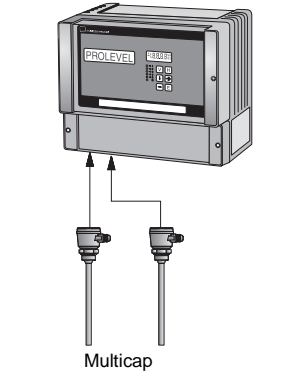
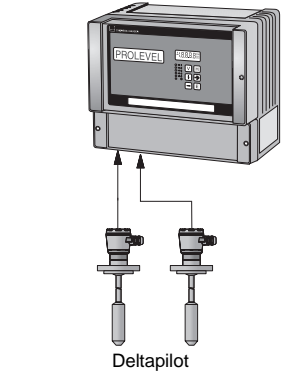
	Prolevel FMC 661	Prolevel FMC 662	Prolevel FMB 662
	 <p>Multicap or Deltapilot Liquiphant Soliphant</p>	 <p>Multicap</p>	 <p>Deltapilot</p>
Applications	Level and volumetric measurement in liquids and bulk solids	Level and volumetric measurement in liquids and bulk solids	Level and volumetric measurement in liquids
Versions	Single-channel transmitter with limit switch input	Two-channel transmitter	Two-channel transmitter
Sensors	One capacitive or hydrostatic probe, optionally Liquiphant or Soliphant limit switch	Two capacitive probes, e.g. of the Multicap series	Two Deltapilot S hydrostatic probes
Extra functions	<ul style="list-style-type: none"> <li>• Vessel linearisation</li> <li>• Independent limit detection</li> <li>• Automatic calibration correction for changing media</li> </ul>	<ul style="list-style-type: none"> <li>• Vessel linearisation</li> <li>• Differential measurement between two levels</li> <li>• Level measurement with reference probe</li> </ul>	<ul style="list-style-type: none"> <li>• Vessel linearisation</li> <li>• Differential measurement between two levels</li> <li>• Density compensated level measurement</li> <li>• Dry calibration without filling the vessel</li> </ul>
Limit value/ Fault indication	Two sets of two relays, each set monitoring a limit value; one alarm relay		
Options	Display with keypad Illuminated display with keypad Rackbus RS-485 interface		
Certificates	CENELEC EEx ia, FM AIS, CSA AIS		
Protection	IP 66		
Documentation	Technical Information TI 232 F/00/en	Technical Information TI 233 F/00/e	Technical Information TI 234 F/00/e

Endress+Hauser  
 GmbH+Co.  
 Instruments International  
 P.O. Box 2222  
 D-79574 Weil am Rhein  
 Germany  
 Tel. (07621) 975-02  
 Tx 773926  
 Fax (07621) 975345

**Endress + Hauser**  
 Nothing beats know-how

