

Level Limit Switch *nivotester FTL 370, FTL 372*

**With intrinsically-safe signal circuits
for connection to sensors
Liquiphant, Nivopuls, Soliphant.**



Features at a Glance

- High operational reliability with:
 - interference-immune PFM signal transmission
 - cable monitoring right up to the piezocrystal drive in the sensor
 - monitoring of corrosion at the forks on the Liquiphant sensor
 - Simple functional test of overspill protection when connected to Liquiphant M: the pressing of a button suffices
- Racksyst plug-in board in Euroformat to DIN 41494, 4 HP wide, 3 HU high
- The same instrument for mounting in 19" racks or Monorack housings
- Intrinsically-safe signal circuits (Ex ia) for safe sensor operation in explosion-hazardous areas

Applications

- Limit detection in vessels containing liquids or solids, and for use in explosion hazardous areas, Zone 0 or Zone 10
- Liquid detection in pipes for dry run pump protection
- Two-point control in one vessel (FTL 372)
- Overfill protection of tanks containing flammable or non-flammable, water polluting liquids

Versions

Nivotester FTL 370 for connecting *one* sensor having two separate output relays and operating in different or identical fail-safe modes.

Nivotester FTL 372 for connecting *two* sensors *two* separate limit switches each having one output relay or *one* two-point controller with two output relays operating in different or identical fail-safe modes.

Endress + Hauser

The Power of Know How



Measuring System

- a) Limit detection in a tank containing liquid with *one* Liquiphant sensor
FDL 30, FDL 31, FDL 35, FDL 36, DL 17 Z or Nivopuls
FDU 10 C, FDU 10 S
- b) Limit detection in a silo containing bulk solids with *one* Soliphant sensor
DM 90 Z, DM 91 Z, DM 92 Z, FTM 30 S, FTM 31 S, FTM 32 S
- c) Limit detection in a tank *and* in a silo
- d) Two-point detection in one tank

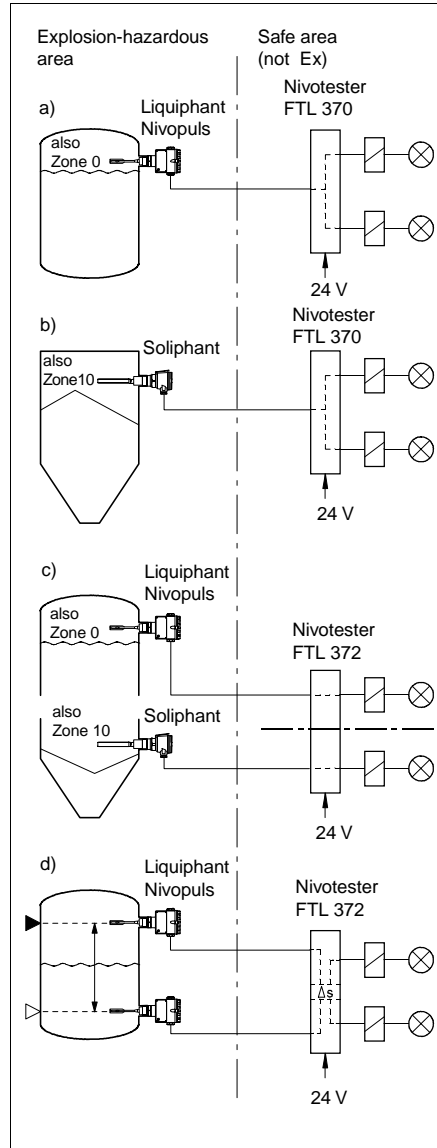

Single Measuring Point

The measuring system consists of:

- a Liquiphant, Nivopuls or Soliphant sensor
- Nivotester FTL 370
- Monorack II (4 HP) *)

Double Measuring Point or Two-Point Control

The measuring system consists of:

- two Liquiphant, Nivopuls or Soliphant sensors
- Nivotester FTL 372
- Monorack II (4 HP) *)

Two different sensors can also be connected to the Nivotester FTL 372, e.g. one Liquiphant for limit detection in liquids and one Soliphant for limit detection in bulk solids.

*) Monorack II (4 HP) is a housing with Protection IP 40 for the Nivotester. The integrated power pack (different versions available) enables wide range AC or DC power supplies to be connected up.

A Large Number of Measuring Points

The measuring system consists of:

- two Liquiphant, Nivopuls or Soliphant sensors per Nivotester FTL 372
- Racksyst assembly rack

Operating Principle

Nivotester FTL 370

The Nivotester FTL 370 is a limit switch with *one* sensor circuit.

Signal transmission

The intrinsically-safe input of the Nivotester FTL 370 limit switch is electrically isolated from other circuits by a DC transformer and an optocoupler.

The Nivotester powers the Liquiphant, Nivopuls or Soliphant sensor with DC current over a two-wire cable and receives a frequency signal which indicates whether the sensor is covered (approx. 50 Hz) or free (approx. 150 Hz). The power supply is superposed with pulses of approx. 200 μ s and a current strength of approx. 10 mA.

Signal evaluation

The Nivotester evaluates the frequency received and activates the switch of both level alarm relays. The covering status of the sensor and the switching status of each relay is indicated by LEDs on the front panel of the Nivotester.

Fail-safe mode

By selecting the appropriate fail-safe mode the relay will always operate in no-load current mode.

Minimum fail-safe mode:

The relay de-energises if the level falls below the switchpoint (sensor is free) or the power supply cuts out.

Maximum fail-safe mode:

The relay de-energises if the level exceeds the switchpoint (sensor is covered) or the power supply cuts out. The fail-safe mode can be freely selected for each relay.

Function monitoring

The Nivotester is fitted with a function monitoring facility to increase process safety. A fault is indicated by an LED and the fault and limit value relays also de-energise.

A fault is indicated if the Nivotester no longer receives an input signal, e.g. on short-circuiting or breakage of the signal line to the sensor, corrosion of the fork of the Liquiphant, defective sensor electronics or input circuit of the Nivotester. The function monitoring can be checked at the test jack on the front panel.

Simple functional test for Liquiphant M

Regular functional tests are often mandatory for overspill protection systems. For the limit detector Liquiphant M, the function of the fork and electronic insert FEL 57 can be tested without changing the level in the tank. The switching unit Nivotester FTL 37#-F2E1 has a pushbutton on the front panel for each signal input. When the button is pressed, the electronic insert FEL 57 in the Liquiphant M simulates various switching states. The LEDs on the Nivotester FTL then show if the Liquiphant M is still in working order. If the device is defective, the Nivotester responds with an alarm.

Nivotester FTL 372

The Nivotester FTL 372 is a double limit switch. It can be operated as two totally independent limit switches, each with one output relay or as a two-point controller with two output relays. It has a common relay for fault indication only.

Function of **limit detection** is dependent on the level and the fail-safe mode (FTL 370 and FTL 372)

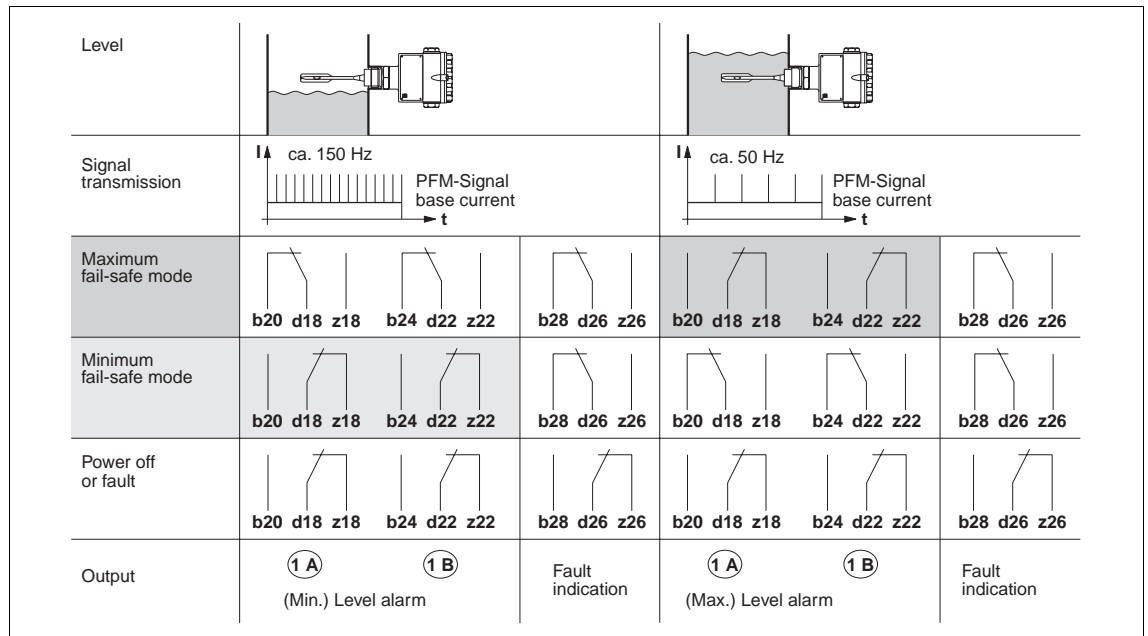

Function of **two-point detection** is dependent on the level and the fail-safe mode (FTL 372 only)

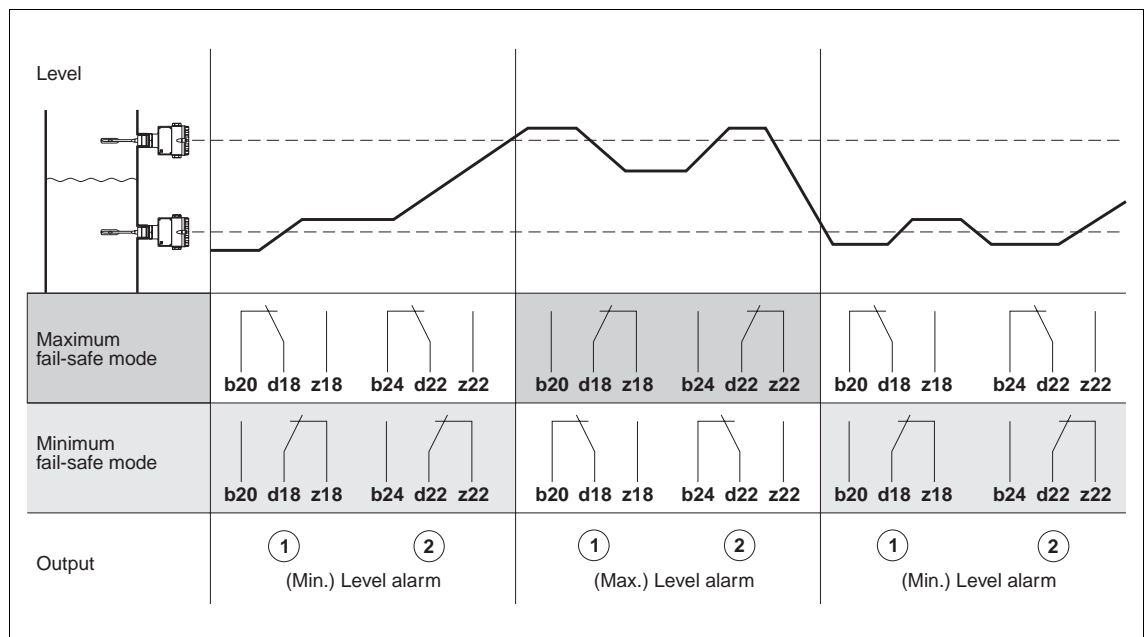

Planning and Installation

The Racksyst plug-in board Nivotester FTL... must be installed outside the explosion-hazardous area in a rack or protective housing. E+H offers:

- 19" wide Racksyst assembly rack for mounting in the control room. This has slots for 21 Nivotester FTL... transmitters mounted side by side.
- 1/2-19" wide Racksyst field housing with Protection IP 65 for 10 Nivotester transmitters.
- Monorack II housing for 4 HP wide plug-in boards (Protection IP 40) for individual or row mounting. A protective housing (IP 55) is also available for mounting the Monorack housing in the open.

See Section "Supplementary Documentation".

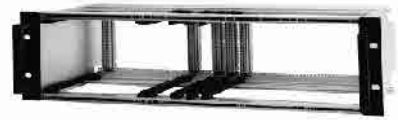

Electrical Connection

Connecting the Power Supply

Note the DC tolerances for DC power and the residual ripple as given in the technical data.

The Nivotester has reverse polarity protection.

A fuse is incorporated into the circuit of the power supply so that a fine-wire fuse is not required.

Connecting the Sensors

Nivotester FTL and the Liquiphant, Nivopuls or Soliphant sensors can be connected together by means of screened or unshielded 2-core installation cable or 2 cores of a general purpose, multicore cable. Cable resistance max. 25 Ω per core. Screened cable is to be used if strong electromagnetic interference is to be expected, e.g. by machines or walkie-talkies. Connect the screening to the ground connection in the sensor; not to the Nivotester.

Using the Sensors in Explosion-Hazardous Areas:

All local regulations covering explosion hazardous areas must be observed with regard to the type of sensor and to the laying of intrinsically-safe wiring. Max. permissible values for capacitance and inductance are given in the certificate of conformity.

When the FTL 372 is to be connected to one sensor in an explosion hazardous area and another sensor in a non-explosion hazardous area, then the cabling of *both* sensors must conform to regulations governing explosion protection.

A suitable female connector should be ordered if the sensor is to be installed in an explosion-hazardous area and the Nivotester is mounted in a rack not supplied by E+H. This connector is only partly fitted with contacts and has the required creep paths and air gaps. It is also supplied with coding pins to ensure that only a Nivotester FTL 370 or FTL 372 can be plugged into it.

Connecting the Signal and Control Units

Note that relay function is dependent on level and the fail-safe mode. If a unit with high inductance is to be connected (e.g. relay, solenoid valve), then a spark arrester should be connected to protect the relay contact. The relay contacts may be subjected to loads as given in the technical data even when one contact is connected to a low voltage circuit with safe isolation.

Left:
Coding pins
ensure that
only the correct
instrument is mounted
in the slot

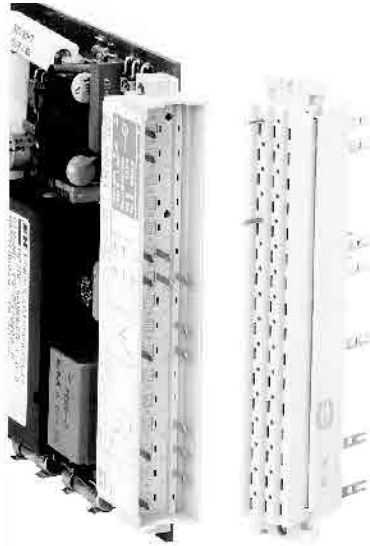

Far right:
Position of coding
pins in the
female connector of the
Nivotester level limit
switch,
left for FTL 370,
right for FTL 372,
as seen from the
plug side of the female
connector

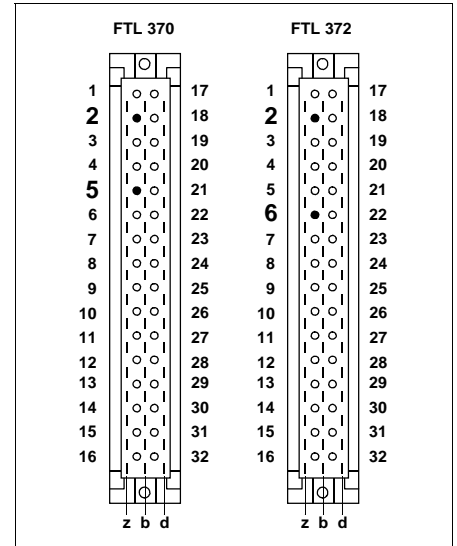

Connection of the
Nivotester FTL 370
level limit detector,
as seen from the
connection side of the
female connector

***Sensors:**
Liquiphant
FDL 30, 31, 35, 36
DL 17 Z
Nivopuls
FDU 10 C, FDU 10 S
Soliphant
DM 90, 91, 92 Z
FTM 30, 31, 32 S

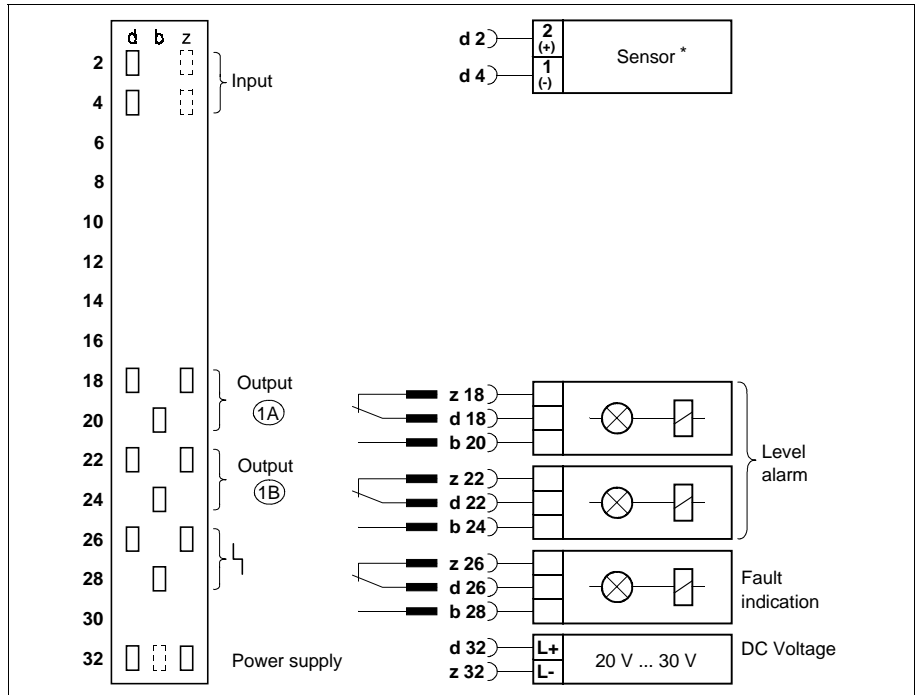

Connection of the
Nivotester FTL 372
two-point level limit
detector, as seen from
the connection side of
the female connector

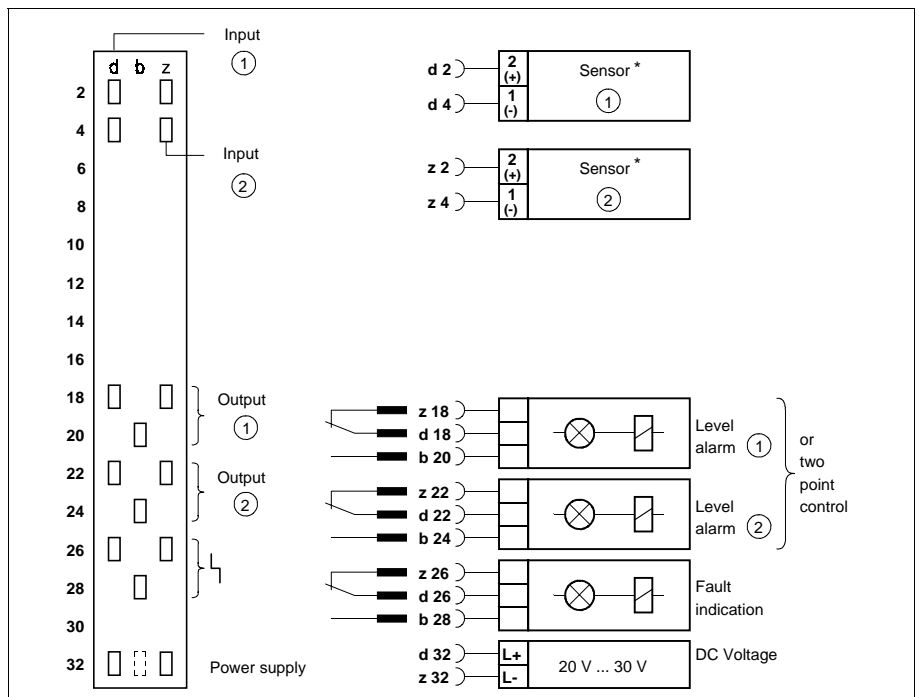

Technical Data

Construction

Racksyst plug-in board: DIN 41494,
d = 160 mm, h = 100 mm
(Euroformat)

Front panel: black plastic
with embossed blue field,
with handle and tag marking area

Width: 4 HP (20.3 mm)

Height: 3 HU (128.4 mm)

Plug connection: male connector
to DIN 41612, Part 3, Type F,
(reduced) 16-pole assembly
for "Monorack II" ("Racksyst II")

Coding holes in the male connector,
FTL 370: Pos. 2 and 5

Coding holes in the male connector,
FTL 372: Pos. 2 and 6

Protection to DIN 50040:
Front panel IP 20, plug-in board IP 00

Weight FTL 370: 150 g

Weight FTL 372: 160 g

Operating Data

Permissible ambient temperatures:
Nominal range: 0 ... +70 °C (30 ... 160 °F)
Operating limits:
-20 °C ... +80 °C (0 ... 180 °F)
Storage: -25 °C ... +85 °C

Climatic class to DIN 40040: K S E

Immunity to electromagnetic
interference: 12 V/m, 10 kHz to 1 GHz,
according to IEC 801-3
(DIN VDE 0843, Part 3)
and NAMUR

Power Supply

DC: 24 V, (20 ... 30 V)

Permissible residual ripple within
tolerance: $U_{pp} = 2$ V

Current consumption: max. 90 mA

Power consumption at 24 V: max. 2.1 W

Power consumption at 30 V: max. 2.7 W

Integrated fine-wire fuses and protection
against reverse polarity

Electromagnetic compatibility:

- Emission to EN 50 081-1
- Immunity to EN 50 082-2
- For general references to
electromagnetic compatibility
see TI 241F/00/en.

Signal Input

Input FTL 370: electrically isolated from
other circuits

Inputs FTL 372: electrically isolated from
other circuits, common power supply

Sensors:

Liquiphant DL 17 Z, FDL 30, FDL 31,
FDL 35, FDL 36,
Nivopuls FDU 10 C, FDU 10 S,
Soliphant DM 90 Z, DM 91 Z, DM 92 Z,
FTM 30 S, FTM 31 S, FTM 32 S

Sensor power supply:
from the Nivotester FTL 370, FTL 372

Connecting cable:
two-core, unscreened or screened
Cable resistance max. 25 Ω per core

Signal transmission:
Pulse Frequency Modulation

Spark protection:
Intrinsic safety [EEx ia] IIC

Further specifications are given in the
certificate

Output

FTL 370:
two relays each with one potential-free
change-over contact for level alarm,
one relay with potential-free
change-over contact for fault indication

FTL 372:
one relay with potential-free
change-over contact per switching
circuit for level alarm,
one common relay with potential-free
change-over contact for fault indication

Fail-safe mode:
minimum/maximum fail-safe mode
for level alarm relay, switchable

Switching delay: approx. 0.5 s

Switching capacity of relay contacts:

U_{\sim} max. 250 V,

U_{-} max. 100 V,

I_{\sim} max. 2,5 A,

P_{\sim} max. 600 VA at $\cos \varphi = 1$,

P_{\sim} max. 300 VA at $\cos \varphi \geq 0,7$,

P_{-} max. 100 W

Also connection to low voltage circuits
to DIN/VDE 0160/5.88, Sect. 5.5.2.1:
up to max. switching capacity of the
relay contacts

Function display:
three LEDs per switching circuit

Fault indication:
one LED per switching circuit

Subject to modification

Dimensions

All dimensions in mm
 100 mm = 3.94 in
 1 in = 25.4 mm

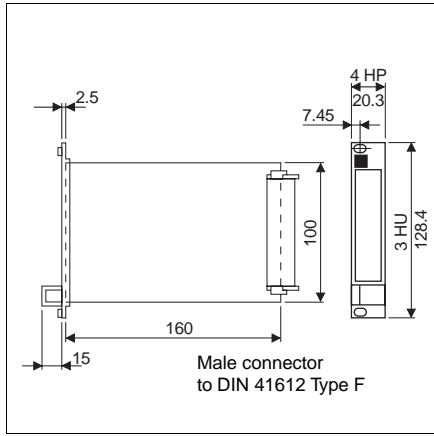

Dimensions of the Racksyst Nivotester FTL... plug-in board

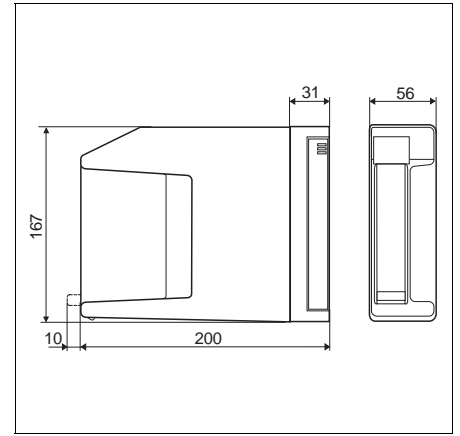

Dimensions of the Monorack II for single mounting of a 4 HP wide Racksyst board

Product Structure

Nivotester FTL 370, FTL 372

Type	FTL 370	Single-channel level limit switch
	FTL 372	Two-channel level limit switch or two-point controller

Certificate, Approval

F	PTB [EEx ia] IIC T6 (Zone 0), overfill protection VbF and WHG
	ATEX II (1) GD
O	FM, AIS, Cl. I, II, III, Div. 1, Gr. A, B, C, D, E, F, G
S	CSA, IS, CL. I, Gr. A, B, C, D, Cl. II, Gr. E, F, G, Cl. III

Version

1	Racksyst, plug-in card, 4 HP
2	Racksyst, plug-in card, 4 HP, for connection to Liquiphant M with button(s) for overspill protection functional test

Power supply

E	20 ... 30 V DC
---	----------------

Output limit signal and fault indication

1	3 SPDT, potential-free contacts
---	---------------------------------

FTL	3	7		-				E	1
-----	---	---	--	---	--	--	--	---	---

complete product designation

How to Order

Nivotester

Product designation as given in product structure or special version as required

Accessories

Mounting accessories
 as required:

- Monorack II, (4 HP)
- Monorack protective housing
- Female connector for FTL 370 or for FTL 372 (Installation kit 16/2)
- Racksyst assembly rack
- Racksyst field housing

Sensors

- Liquiphant for liquids
- Nivopuls for liquids
- Soliphant for bulk solids

See the appropriate technical documentation for ordering accessories

Supplementary Documentation

Mounting

- Racksyst System summary
SI 008F/00/e
- Monorack II housing
for single mounting of the Nivotester
in the control room
TI 183F/00/en

Certificates

- Certificate of conformity
(CENELEC)
PTB No. Ex-93.C.2032 X
ZE 077F/00/a3

Other certificates on request

Safety instructions for explosion-hazardous areas

- XA 049F/00

Sensors

- Liquiphant II
FDL 30, FDL 31, FDL 35, FDL 36,
Sensors for limit detection in liquids
TI 185F/00/en
- Liquiphant M
FTL 50, 51, FTL 50 H, 51 H
Sensors for limit detection in liquids
TI 328F/00/en
- Nivopuls FDU 10 C
Non-invasive sensor for
limit detection in liquids
TI 248F/00/en
- Nivopuls FDU 10 S
Non-invasive sensor for
limit detection in liquids
TI 275F/00/en
- Soliphant
FTM 30 S, FTM 31 S, FTM 32 S
Sensors for limit detection in bulk solids
TI 249F/00/en

Replacing the Instrument

Replacing a FTL 170 Z by the FTL 370 or the FTL 372

The Nivotester FTL 170 Z can be generally replaced by the Nivotester FTL 370 (for one-channel mode) or by the Nivotester FTL 372.

Please note, however:

- The male connector of the Nivotester FTL 370 or the FTL 372 Racksyst board has a different coding to that of the Nivotester FTL 170 Z Racksyst board.
When replacing, the female connector in the rack must be replaced and rewired.

- If the Nivotester FTL 170 Z is mounted in the Monorack, then the complete unit must be replaced by the Nivotester FTL 370 or FTL 372 in the Monorack II.

Endress+Hauser
GmbH+Co.
Instruments International
P.O. Box 2222
D-79574 Weil am Rhein
Germany

Tel. (0 76 21) 975-02
Tx 773926
Fax (0 76 21) 975-345
<http://www.endress.com>
info@ii.endress.com

